

# AquaJack<sup>®</sup> 211

## Electric cordless rechargeable pool and spa vacuum cleaner Instruction manual

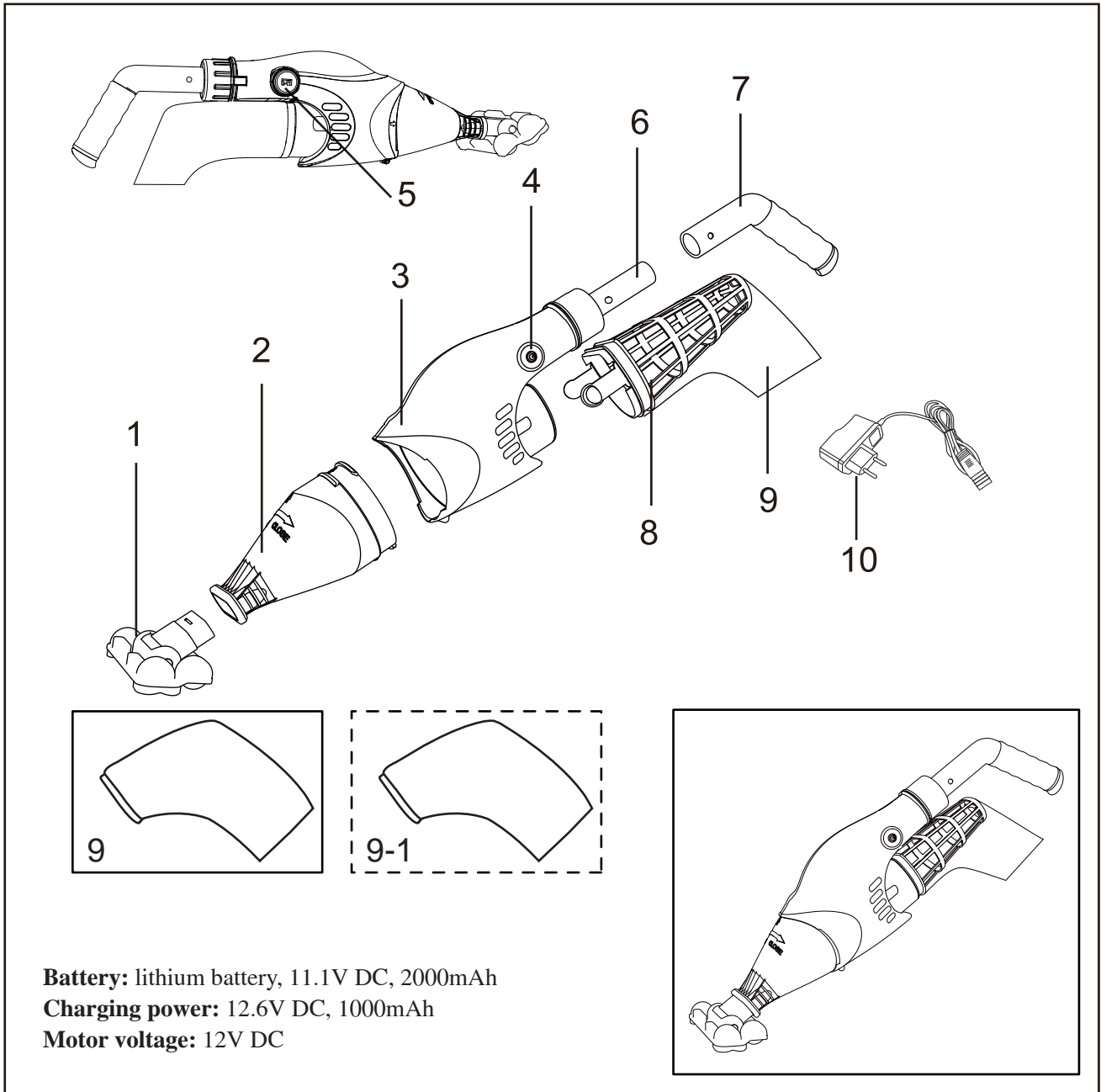

1. Vac head
2. Front filter
3. Cleaner body
4. Switch
5. Charging position
6. Poles fitting
7. Portable handle
8. Filter basket
9. Large mesh filter bag
- 9-1: Fine material filter bag  
(optional, not with shipment)
10. Charger

## **SAFETY WARNING**

The cleaner is not a toy, and is operated by people older than 8 years age. Any people who operates the cleaner, has to read the manual carefully before work it.

- (1)The cleaner is designed to clean the swimming pool, SPA.
- (2)Please use the original batteries and charger when using.
- (3)Only charging it when the cleaner is power off.
- (4)Put the cleaner into a clean and dry place. Do not expose it under the sun, or close to explosive.
- (5)The filter bag is easy to be broken when there is sharp substances under water.
- (6)Do not work it when out of water.
- (7)Do not close to the vacuum head when it is working, due to its suction power, especially for the human body, animals, hairs or clothes.
- (8)Do not disassemble the cleaner without professional guidance or notice from the authorized distributor or manufacturer.
- (9)Do not leak the lubricant oil, and it causes water polluted.
- (10)Stop to work the cleaner when there is anything wrong; Please contact with the authorized distributor or replace it to the original parts/accessories.
- (11)Cleaner working conditions:
  - (11)-1 Water depth from 30cm to 300cm
  - (11)-2 Water temperature: 4°C( 39.2°F )-35°C( 95°F )

### **1. Charger**

- (1)Use the original charger provided only.
- (2)For indoor use only. The charger should not be used outdoor and not be exposed to rain, humidity, any liquid or heat.
- (3)Keep the charger out of children.
- (4)Never use the charger if any damage is found.
- (5)Do not handle the cleaner and charger with wet hands and bare feet , when charging the cleaner.
- (6)Disconnect the charger from power when not in use.
- (7)If the wire is damaged, it must be replaced by a new charger to avoid danger.

- (8) Make sure the cleaner and charger are totally dry before charging.
- (9) Charge the cleaner 3 hours prior to the first use. Normally cleaner can be operated about 60 minutes after fully charged.

## **2. Battery disposal**

- (1) The cleaner battery is a lithium battery, it must be disposed properly, please contact with your local authority for more information.
- (2) Never attempt to disassemble the lithium battery.
- (3) Remove all personal items such as rings, bracelets, necklaces and watches when unwiring a lithium battery from the vacuum unit.
- (4) The battery causes short circuit current, as well as severe burning when it is high enough.
- (5) Wear complete eye protection, gloves and protective clothing when removing the battery pack.
- (6) No smoking or sparkling flame near the cleaner, or, it may cause unknown gases.
- (7) If acid comes in contact with skin and clothing, wash immediately with plenty of soap and water.
- (8) If acid comes in contact with eyes, immediately flood eye with running cool water for at least 15 minutes. Get medical attention immediately.

**Above warning and cautions are not intended to incorporate all possible instances for risks and/or severe injury.** Pool/spa owners should always exercise intensive caution and common sense when operating the cleaner.

# How to use ?

## 1. How to connect with charger ?

(1) Before connection to the cleaner, firstly connecting the charger with socket to check the charger quality, when the light is green, the charger is ok; Then, connecting to the cleaner, if the light is red, it means the cleaner is charging. (2) Around 3 hours later, the light turns to green, it means the machine is full of power now.

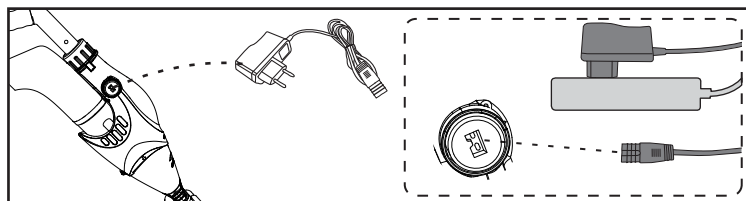

## 2. How to assemble the cleaner ?

### 2.1 Component installation

Please assemble the machine by arrows, especially the signs ON/OFF , OPEN / CLOSE at the body.

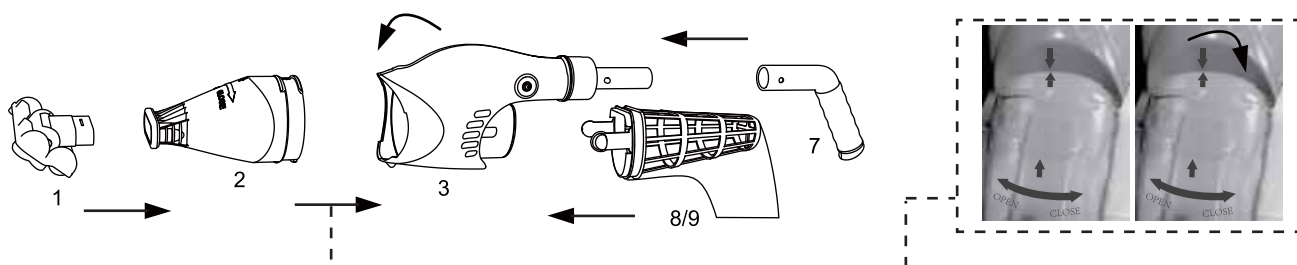

### 2.2 Handle assembly

The cleaner can either connect with portable handle A, or standard telescopic poles B ( B is not with shipment, needs to extra purchase )

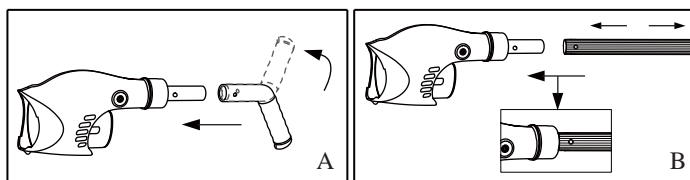

### 2.3 Suction head assembly

Please take the correct way to assemble the vacuum head and front filter, please be sure the front filter way is right, otherwise, the cleaner can not work efficiently. (See, Fig "A" and "B")

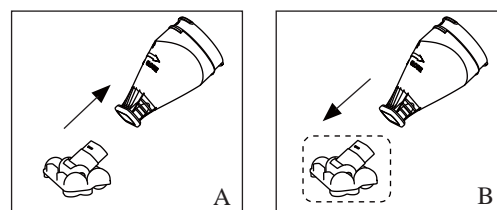

### 2.4 Filter bag assembly

#### 2.4.1 How to choose the correct filter bag?

(1) Large mesh filter bag

It is used for dirty pools, or plenty of rubbish into the pools, such as beginning of season, after big shower or raining.

(2) Fine material filter bag ( It is optional, needs to extra purchase)

It is used for small debris, such as dusts, muds.

## 2.4.2 How to assemble filter bag?

Please take the steps per arrows:

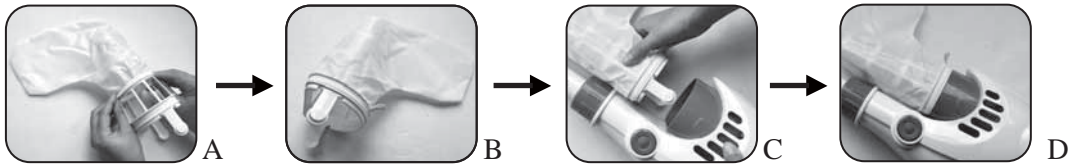

## 3. How to clear the filters?

### 3.1 Wash the front filter

Please follow the pics, and take care of machine sign OPEN/ CLOSE .

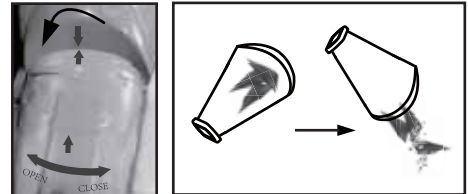

### 3.2 Wash the back filter

Please follow the arrows:

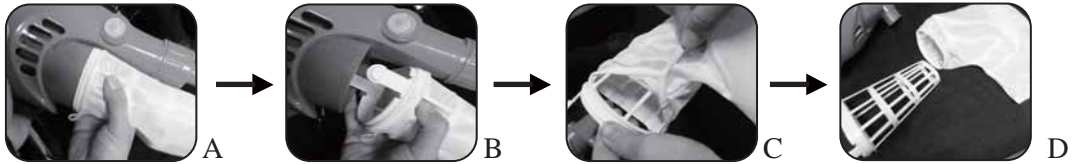

## 4. How to assemble the batteries?

(1) Please follow the pics to get the batteries out.

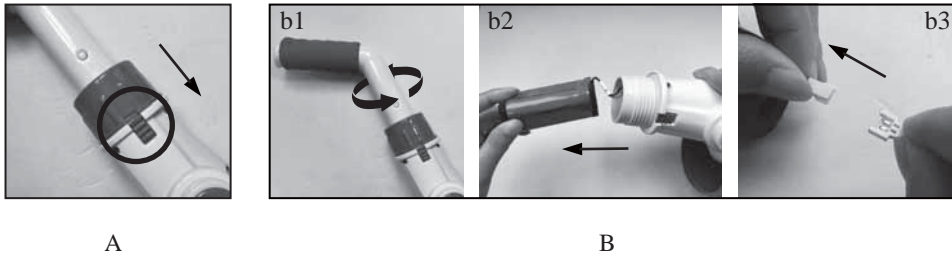

(2) Please follow the pics to put the batteries into.

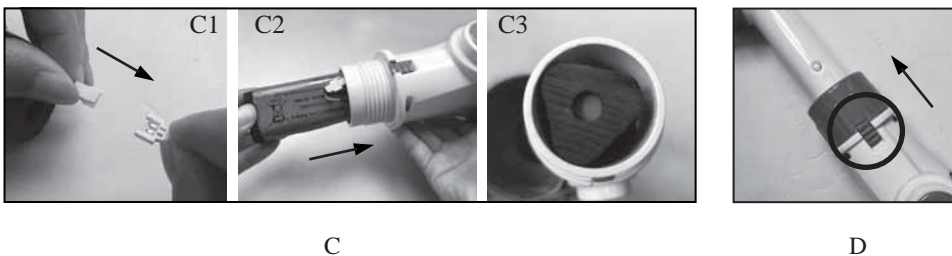

## 5. Trouble shooting

Problem	Possible Cause	Action
Cleaner does not capture the debris	Battery is running out	Charge the battery again. Normally cleaner can operate about 60 minutes after fully charged.
	Impeller is jammed	Power off the cleaner and visually check the gap in middle of the cleaner to see if the impeller is jammed. you can use your hand to rotate the impeller two circles to make the impeller rotation looser. <b>WARNING! Make sure cleaner is power off when servicing the cleaner.</b>
	Impeller is broken	Contact your dealer for impeller replacement.
	When the filter bag is full	Detach the filter basket and filter bag, and clean them.
Garbage flowing out from the Transparent Suction Head part	The soft rubber of the rear impeller is broken	The soft rubber of rear impeller is like a door in case the garbage in the filter bag will flow backwards into impeller and the cover of transparent suction head part.
Garbage flow out from the rear filter bag	Filter sock is damaged	Replace a new filter sock.
Handle/pole connector cannot be secured in assembly	Side pin broken	Using the new V-Shape clip
Cleaner cannot be recharged	Battery is dead	Contact dealer for battery replacement. <b>WARNING! When you replace the battery, please contact the local dealers to purchase the original lithium battery in case that the electric cleaner is destroyed.</b>
	The charger is out of order	Contact dealer for proper transformer. <b>WARNING! Using wrong charger will result in damaging the cleaner /battery and void the warranty.</b>

6.

## Environmental Programmes

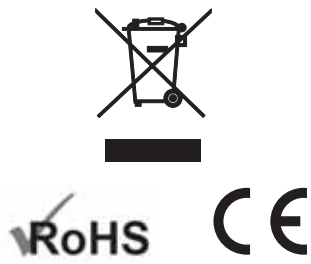

Please respect the local regulations and help to protect the environment.

Return non-working electrical equipment to a facility appointed by your municipality that properly recycles electrical and electronic equipment, Do not dispose them in unsorted waste bins.

For items containing removable batteries, remove batteries before disposing of the product.

We reserve the right to change all or part of the features of the articles or contents of this document, without prior notice.