

**MATRIX**

LSL SERIES

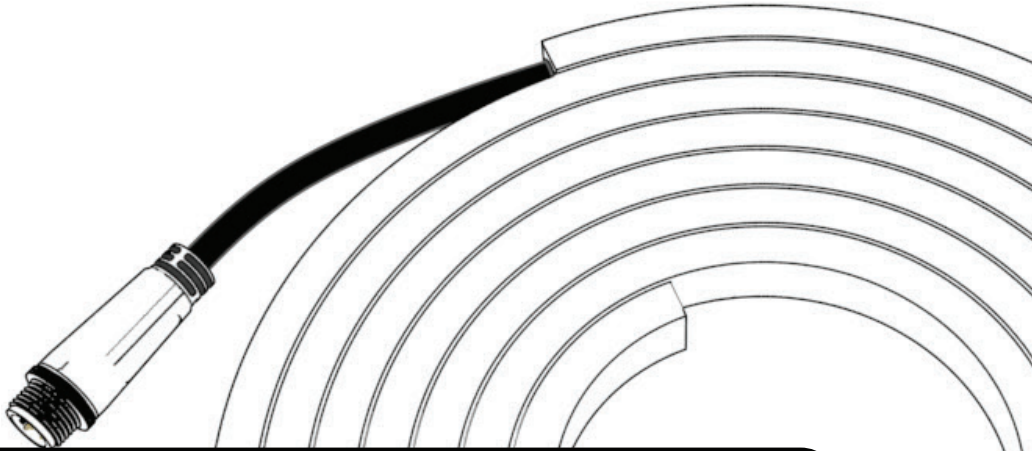

**LANDSCAPE STRIP LIGHT  
INSTALLATION**

**INSTALLATION &  
OWNER'S MANUAL**



# CONTENTS

SPECIFICATIONS		1
READ THIS FIRST		2
INCLUDED PARTS		3
INSTALLATION	MOUNTING	4
	WIRING	6

## SPECIFICATIONS

**INPUT:** 12V AC 2A ONLY

**OUTPUT:** 24V DC 1A MAX

**MAX STRIP LENGTH :** 5 METERS (TOTAL)

**MAX CABLE LENGTH:** 40M - (USE ONLY **MATRIX** EXTENSION CABLES)

**FUSE:** 2A BLADE FUSE

**TOTAL LAMP WATTS:** 25W MAX

## PRODUCT SUPPORT & INFORMATION

Phone: +61 3 9793 2299 (business hours)

Email: [sales@spaelectrics.com.au](mailto:sales@spaelectrics.com.au) (SALES enquiries)

Email: [tech@spaelectrics.com.au](mailto:tech@spaelectrics.com.au) (TECHNICAL support enquiries)

Web: [www.spaelectrics.com.au](http://www.spaelectrics.com.au)

# READ THIS FIRST

Congratulations on your purchase of a **MATRIX** lighting system. All Spa Electrics lights are designed and manufactured in Australia from only the highest quality materials. For more information on Spa Electrics and our products, please visit [www.spaelectrics.com.au](http://www.spaelectrics.com.au)

## BEFORE YOU START:

- **MATRIX** cables are supplied with pre-fitted quick connect plugs to reduce installation hassle and guarantee reliability. These cables should not be cut, joined or modified in any way from their original condition.
- Ensure that the power supply used to operate this system is installed by a qualified person (e.g. Registered pool builder and/or licensed electrician), in accordance with the most current edition and/or amendment of the AS3000 wiring code.
- For safe and proper installation, ensure that only those parts supplied with the system are used.
- Lights should only be mounted in a location that is readily accessible after the installation is complete. Spa Electrics will not be liable for installation of its products in locations that are deemed non-servicable.

## CLEANING

- Only use warm water and a soft brush or cloth to clean **MATRIX** series lights. DO NOT use detergents or spirits as this can damage the light and void your warranty.

## USE

- Operating the light for at least 15 minutes every week is advised (all year round).
- Temperature range for installation, operation and servicing: 0°C ~ +40°C



## WARNING

Minimum power source wattage requirement - 25 Watts per driver.

Maximum total strip light length per driver = 5 Meters

- DO NOT use electronic or switch-mode transformers. These transformers will damage the light and void your product warranty.
- Pool chemicals & PH levels: Due to the corrosive nature of unbalanced pool chemicals, Spa Electrics strongly recommend that your pool water is balanced prior to installing your lights or any plastic or stainless steel components, and tested weekly to maintain these levels. pH levels should be maintained between 7.2 – 7.6 at all times to ensure the longevity of these components.
  - > Failure to do so can result in chemical damage to the light housing and pool fittings, including stainless steel components.
  - > Please note: Lights or components found to have excessive chemical damage will not be covered under our manufacturer's warranty policy

# INCLUDED PARTS

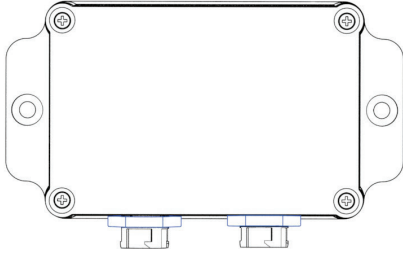

STRIP LIGHT DRIVER

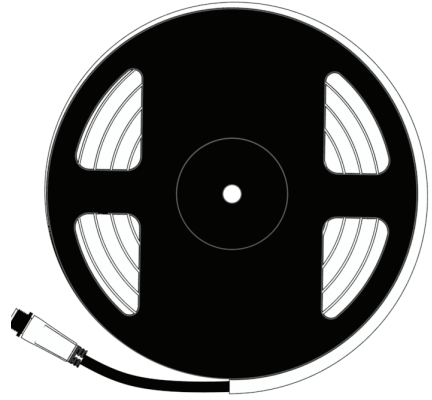

5M STRIP LIGHT

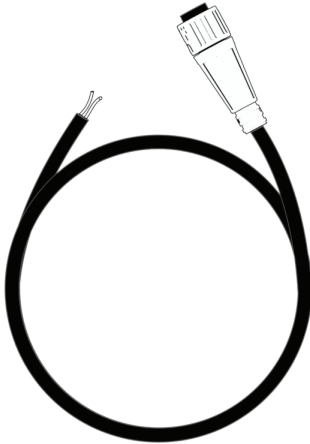

1M INPUT POWER CABLE

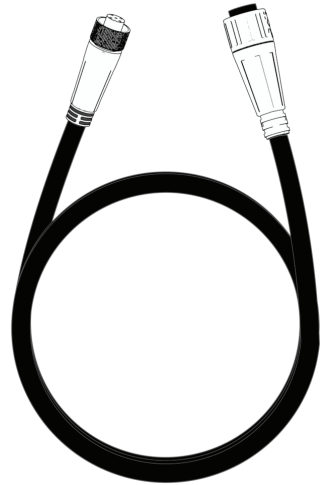

5M STRIP LIGHT  
POWER CABLE



1x  
WARRANTY

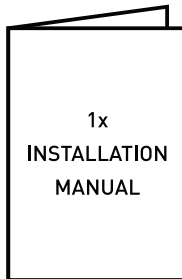

1x  
INSTALLATION  
MANUAL



## NOTE

**ADDITIONAL EXTENSION  
CABLES AVAILABLE IN  
20,30,40M LENGTHS.  
CONTACT SPA ELECTRICS FOR  
MORE INFORMATION.**

# INSTALLATION – MOUNTING

## 1 STEP 1

REMOVE ADHESIVE  
PEEL COAT.



## 2 STEP 2

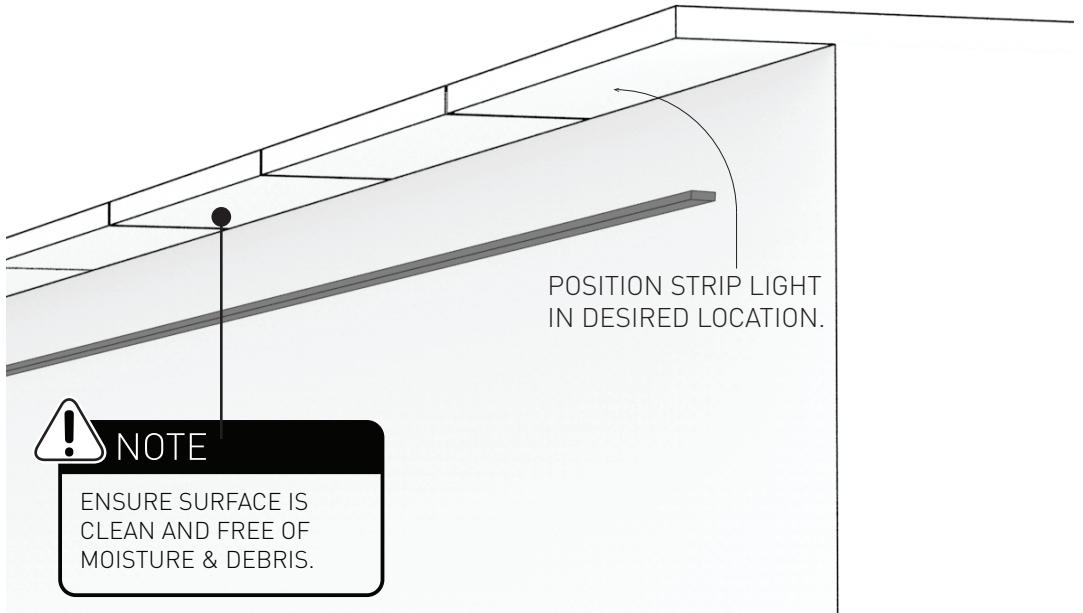

### NOTE

ENSURE SURFACE IS  
CLEAN AND FREE OF  
MOISTURE & DEBRIS.

## 3 STEP 3

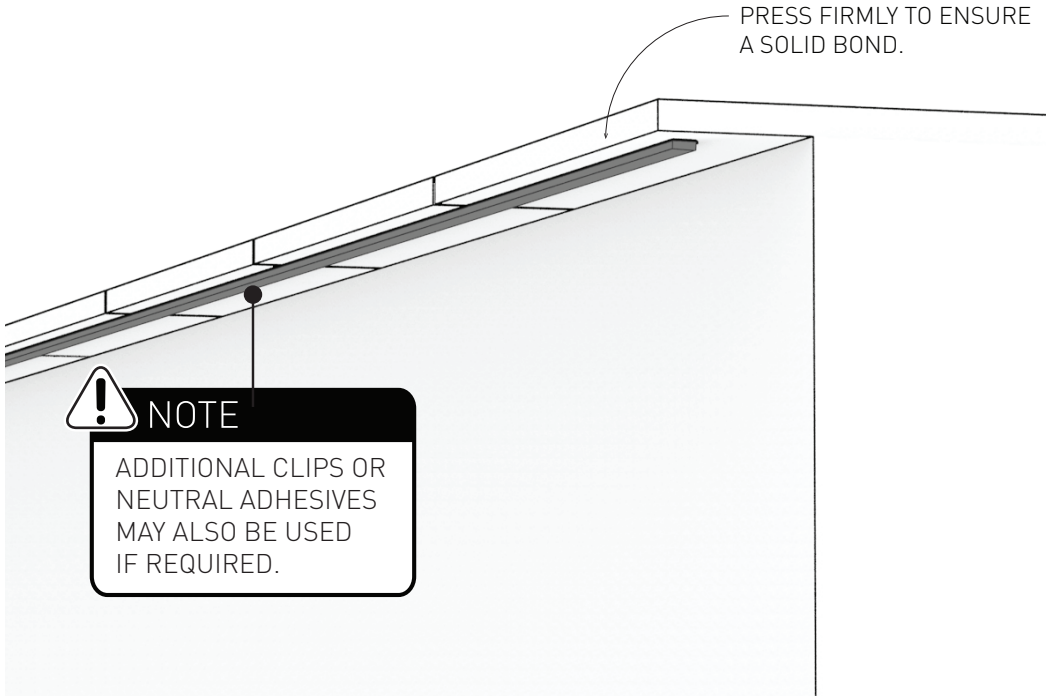

### STRIP LIGHT TOO LONG?

EACH STRIP LIGHT CAN BE SHORTENED BY SIMPLY TRIMMING TO THE DESIRED LENGTH USING A PAIR OF SCISSORS. THERE ARE TRIM MARKS VISIBLE ON THE FRONT AND BACK OF THE STRIP LIGHT TO HIGHLIGHT THE APPROPRIATE TRIM LOCATION.

ONCE THE STRIP LIGHT IS TRIMMED, SIMPLY GLUE THE SPARE END CAP ON THE EXPOSED END USING NEUTRAL SILICONE.

Continue to next section



# INSTALLATION – WIRING

## 1 STEP 1

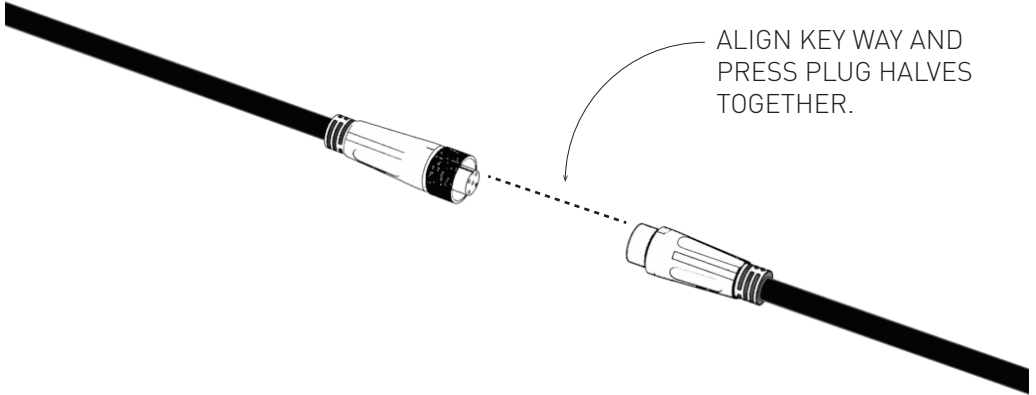

## 2 STEP 2

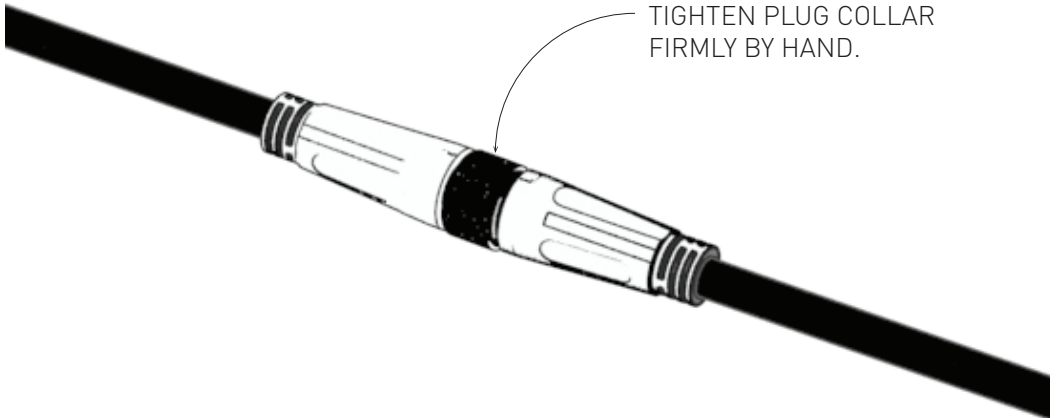

### 3 STEP 3

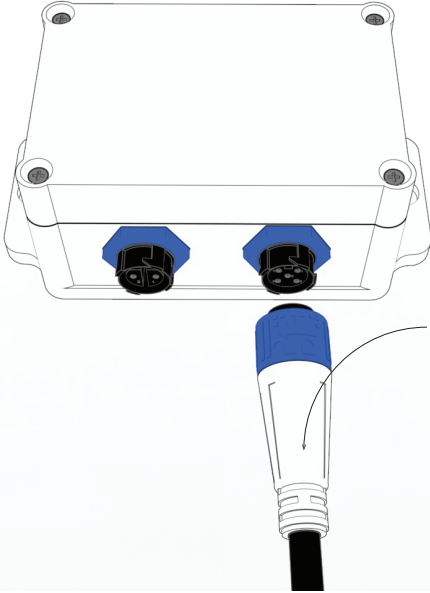

TO STRIP LIGHT  
**5 PIN CONNECTION**

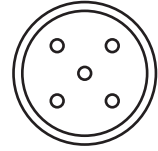

CONNECT STRIP LIGHT  
POWER CABLE TO DRIVER  
BY ALIGNING KEY WAY AND  
PUSHING ONTO MATING  
CONNECTOR.

### 4 STEP 4

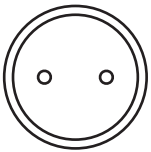

TO 12V AC POWER SUPPLY  
**2 PIN CONNECTION**

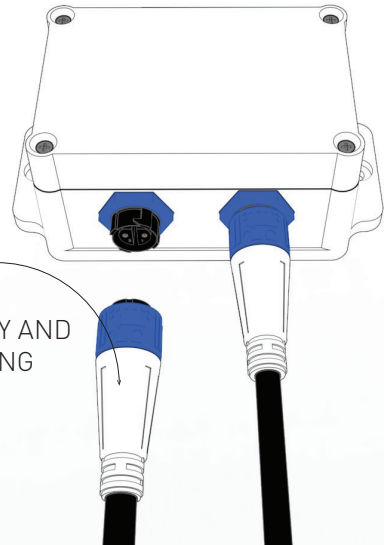

CONNECT INPUT  
CABLE TO DRIVER  
BY ALIGNING KEY WAY AND  
PUSHING ONTO MATING  
CONNECTOR.

# 5 STEP 5



MOUNT THE DRIVER WITHIN 1 METER OF THE CHOSEN POWER SUPPLY.

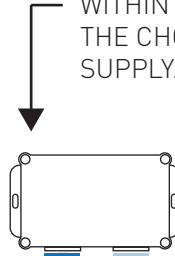

MAX LENGTH 1M



## SYSTEM COMPATIBILITY

This lighting system is compatible with the following power supplies / controllers.

- LiT YARD4 CONTROLLER
- LV SERIES TRANSFORMERS
- iRIS REMOTE CONTROL
- 3rd PARTY POOL CONTROLLERS

TO STRIP LIGHT





**NOTE**

PLEASE STORE THIS  
MANUAL IN A SAFE PLACE  
FOR FUTURE REFERENCE



© COPYRIGHT 2020 SPA ELECTRICS PTY. LTD.  
ALL RIGHTS RESERVED