

SPECK PRO SERIES

Designed to suit all Domestic Pools & Spas



speck
pumps  SPECK

Flow Rates from
230 - 500 Litres per Minute

Quieter, smoother performance

German design & engineering

Available in 1.0 to 2.0 HP

Easy to remove non-corrosive lid with handle

Robust construction, highest quality materials

CONTINENTAL
WATER

Pool Products for Pure Enjoyment

SPECK PRO



The Speck PRO Series is the ideal choice for all domestic pool and spa applications including heating, salt chlorination and automatic pool cleaners.

THE SPECK PRO SERIES

- A high resistance to corrosion and salt water
- Maximum effectiveness at low power input
- The ultimate in reliability
- Stability at high fluid temperatures up to 60°C
- No contact between motor and pump shaft with pool or spa water
- Highest quality mechanical seal
- Fan cooled - suitable for high ambient temperatures
- Closed impeller
- Stainless steel motor shaft
- Easy to remove clear strainer lid
- Every pump factory wet tested for quality control
- Five year warranty

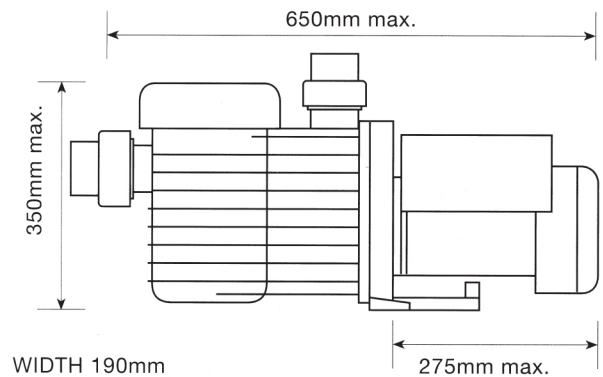

Model Code	Input Watts	Nominal Input HP
PRO 230	1000	1.0
PRO 350	1100	1.25
PRO 400	1300	1.5
PRO 500	1500	2.0
PRO 500 DS (Dual Speed)	300 low 1400 high	0.75 low 2.0 high

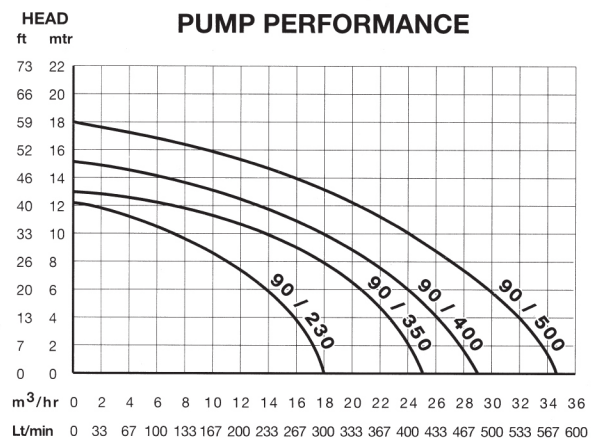

CONTINENTAL WATER Incorporating IBC Water

ABN: 71 050 287 735

1300 166 253 for Sales and Service
e sales@continentalwater.com.au / accounts@continentalwater.com.au

New South Wales Office
t (02) 8814 2800
f (02) 9838 7030

Victorian Office
t (03) 8794 3800
f (03) 9702 3941

Queensland Office
t (07) 3434 1100
f (07) 3219 2266

New Zealand Office
t 0011 64 9570 9570
f 0015 64 9527 7641

